

**SPYDER 120**



## STANDARD FEATURES

- High Torque Drive system
- Extreme Gradeability - market leading
- Rear Oriented Boom position
- Auto Levelling Basket
- Maximum Approach Angle - market leading
- OSHA and ANSI 92.20 Standards certified
- Dual Power Sources - Diesel Engine & standard 110V/60Hz Electricity
- High Pressure Water/Air connection to Basket
- 110V Power Supply to the Basket
- Negative Working Height - market leading
- Remote Management and Diagnostic software
- Radio Control
- Up & Over - market leading
- Invisible Boom
- Self - Loading

## ADDITIONAL/OPTIONAL FEATURES

- |                             |   |
|-----------------------------|---|
| Non-marking Tracks          | Custom Paint Options available (Upper and Lower sections) |
| Brushes for Boom Protection | Auto-close Functionality                                  |
| Optional 1 Man Basket       | Extra Large Basket  |
| Optional Cages              |   |



**TECHNICAL SPECIFICATIONS**

**MEASUREMENTS**

<b>A</b>	Height Stowed with basket	7' 10"
<b>B</b>	Overall Length with basket	25' 0"
	Overall Width with basket	6' 9"
<b>D</b>	Height Stowed without basket	7' 10"
<b>E</b>	Overall Length without basket	25' 0"
	Overall Width without basket	4' 11"
<b>G</b>	Track L x W	8' 4" x 4' 11"
	Length outrigger footprint. Standard	14' 5"
	Width outrigger footprint. Standard	14' 5"
	Length outrigger footprint. One side narrow	17' 9"
	Width outrigger footprint. One side narrow	10' 10"
	Total weight	17196 lbs
	Live load in travelling position	0.986 psi
	Live load in working position	0.479 psi

**PERFORMANCE**

	Platform working height (max)	118' 5"
	Horizontal outreach (max)	50' 10"
	Negative work	- 13'
	Up & over clearance	98' 5"
	Basket Capacity	441 lbs
	Moveable jib	180°
	Basket rotation	180°
	Turret rotation	380°
	Gradeability (max)	23 %
<b>N</b>	Angle of Approach (max with Basket)	23 %
	Max Slope Angle for Stabilization	37 %
	Dual power sources	Diesel / 110V electricity
	Travel speed fast	1.56 mph
	Travel speed slow	1.56 mph

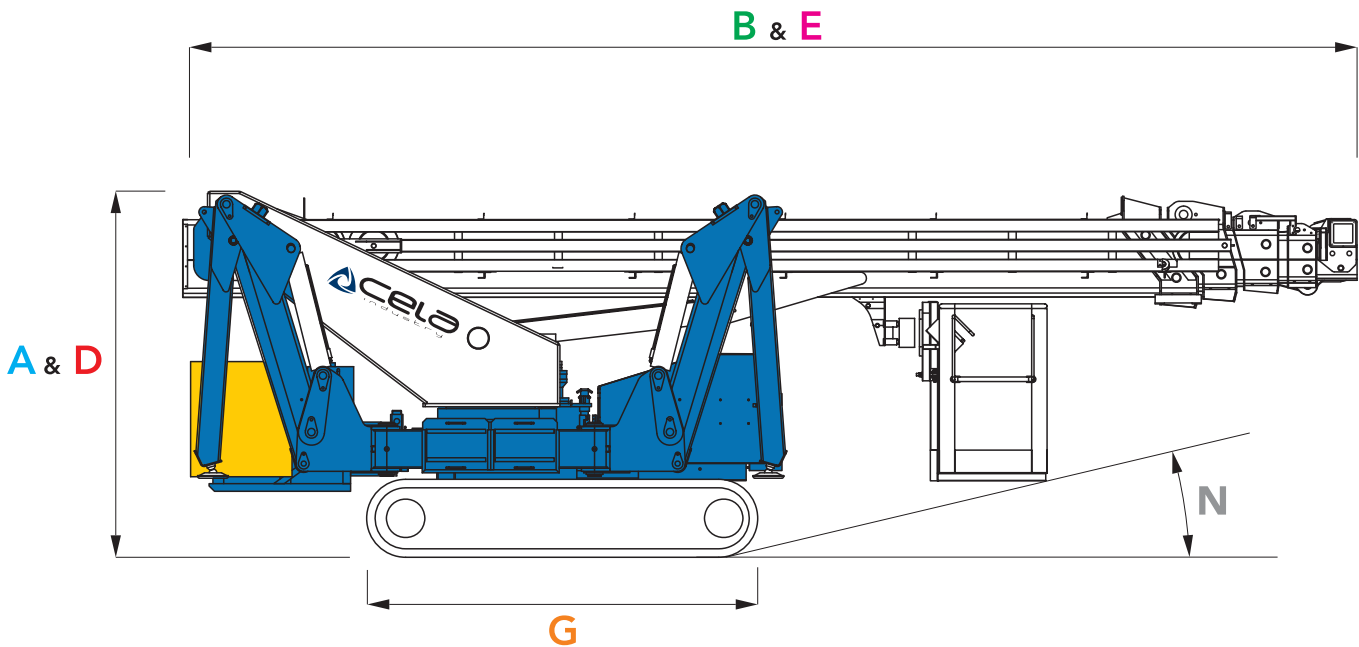

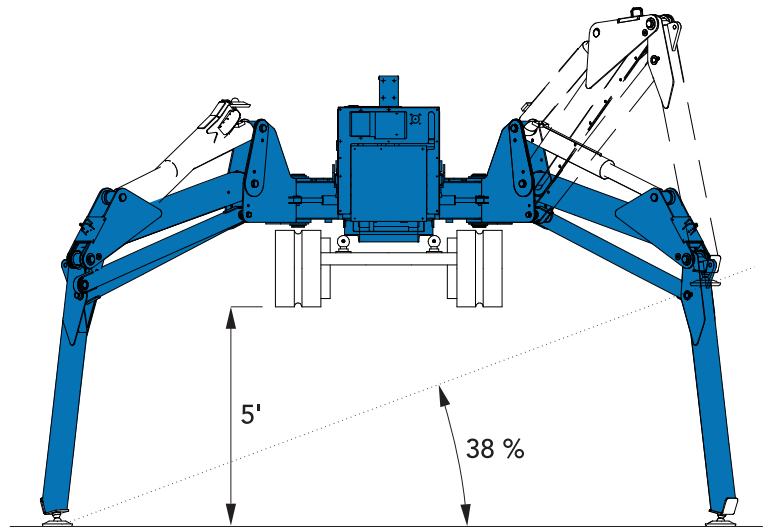
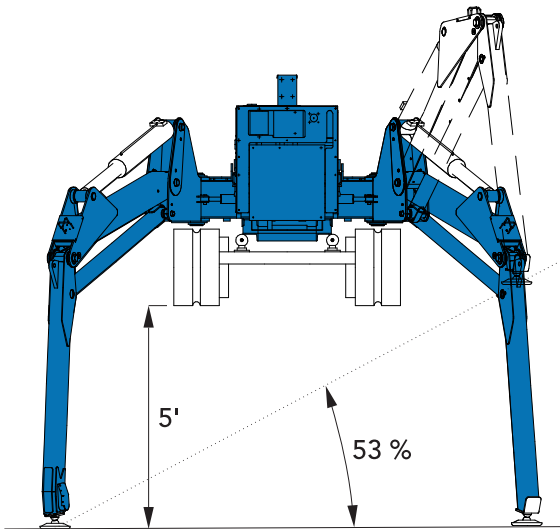
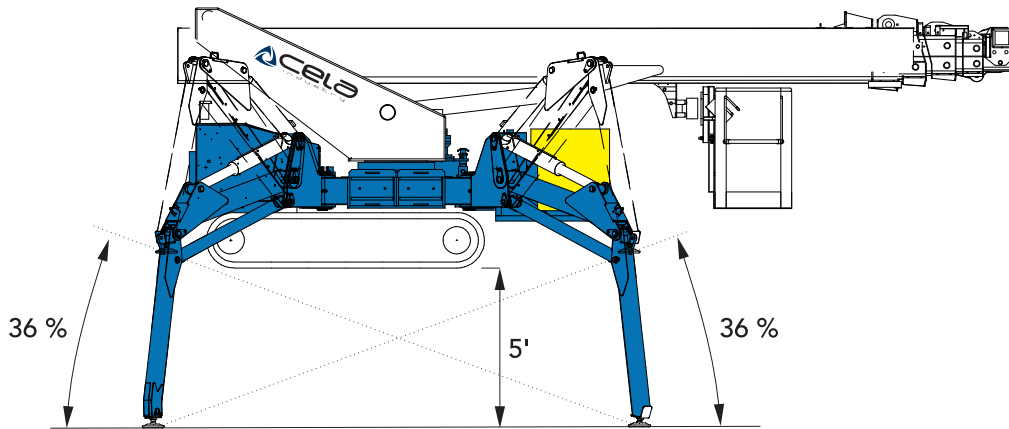
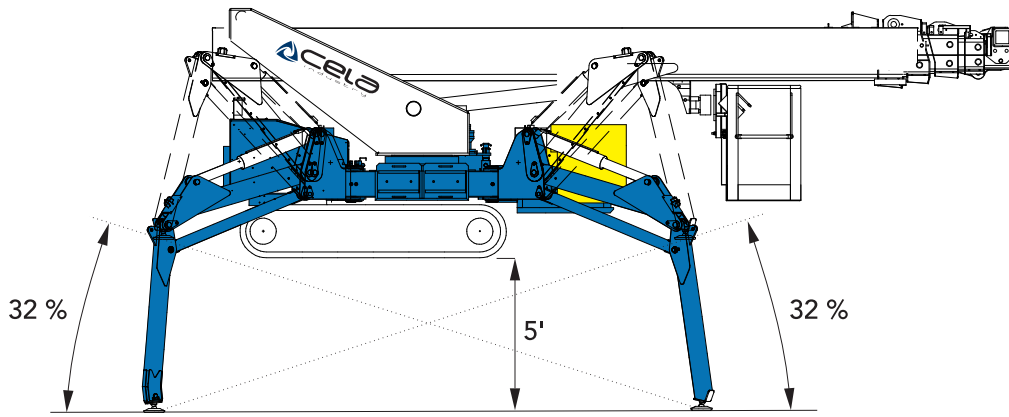

380° CONTINUOUS

