

DT92 **SPYDER**



STANDARD FEATURES

- High Torque Drive system
- Extreme Gradeability - market leading
- Rear Oriented Boom position
- Auto Levelling Basket
- Maximum Approach Angle - market leading
- OSHA and ANSI 92.20 Standards certified
- Dual Power Sources - Diesel Engine & standard 110V/60Hz Electricity
- High Pressure Water/Air connection to Basket
- 110V Power Supply to the Basket
- Automatic Stabilization
- Negative Working Height - market leading
- Remote Management and Diagnostic software
- Radio Control
- Up & Over - market leading
- Invisible Boom

ADDITIONAL/OPTIONAL FEATURES

Non-marking Tracks	Custom Paint Options available (Upper and Lower sections)
Brushes for Boom Protection	Hook & Crane certification
Optional 1 Man Basket	Cage for materials handling
Optional Cages	Extra Large Basket
Optional Crane Hook	Fiberglass Basket
110V Hydraulic Generator	Winch
Auto-close Functionality	

 **LITHIUM version available**



TECHNICAL SPECIFICATIONS

MEASUREMENTS

A	Height Stowed with basket	7' 6"
B	Overall Length with basket	19' 8"
C	Overall Width with basket	5' 11"
D	Height Stowed without basket	7' 6"
E	Overall Length without basket	17' 9"
F	Overall Width without basket	3' 11"
G	Track L x W	6' 2" x 3' 11"
H	Length outrigger footprint. Standard	16' 1"
I	Width outrigger footprint. Standard	14' 1"
L	Length outrigger footprint. One side narrow	19' 3"
M	Width outrigger footprint. One side narrow	10' 2"

Total weight	10803 lbs
Live load in travelling position	1.023 psi
Live load in working position	0.334 psi

PERFORMANCE

Platform working height (max)	91' 10"
Horizontal outreach (max)	45' 11"
Negative work	- 19' 8"
Up & over clearance	52' 6"
Basket Capacity	772 lbs
Hook Capacity	860 lbs
Basket rotation	180°
Turret rotation	360°
Gradeability (max)	40 %
Angle of Approach (max with Basket)	42 %
N Angle of Approach (max without Basket)	40 %
O Max Slope Angle for Stabilization	27 %
Dual power sources	Diesel / 110V electricity
Travel speed fast	1.32 mph
Travel speed slow	0.59 mph

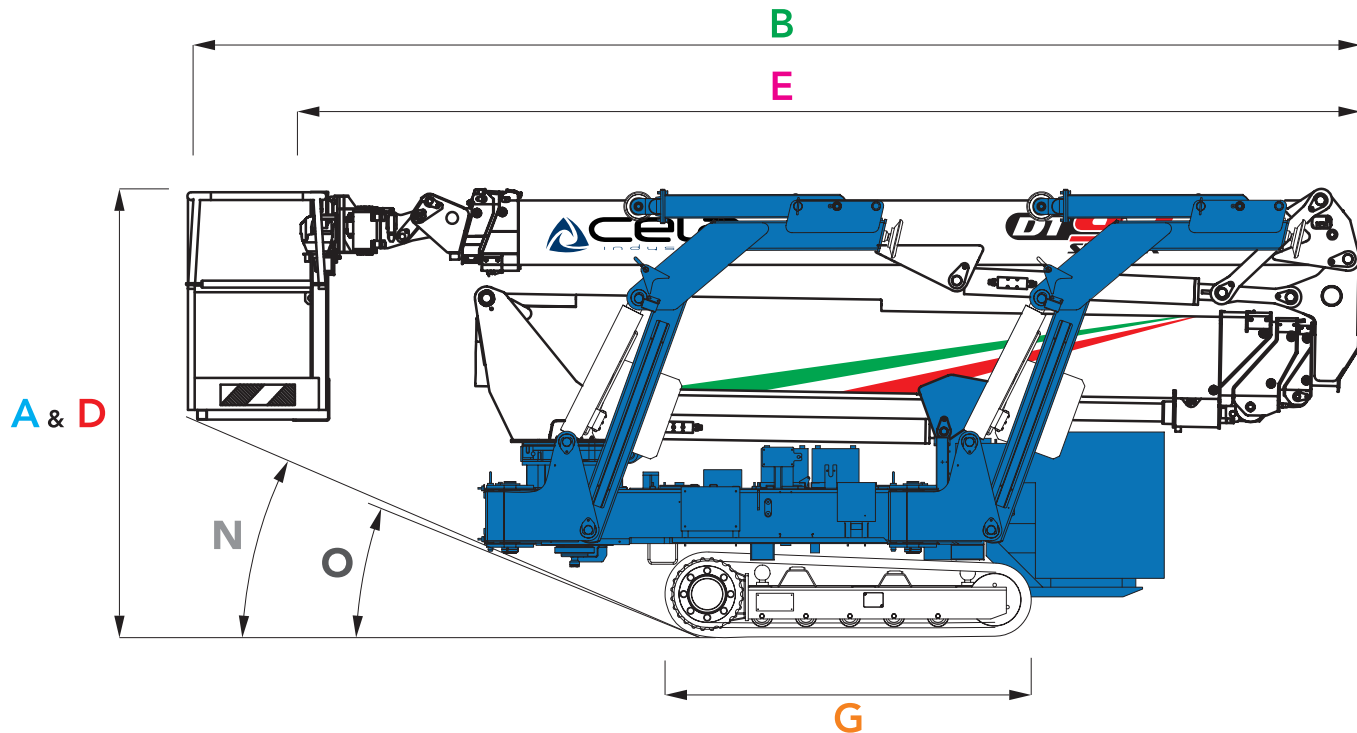

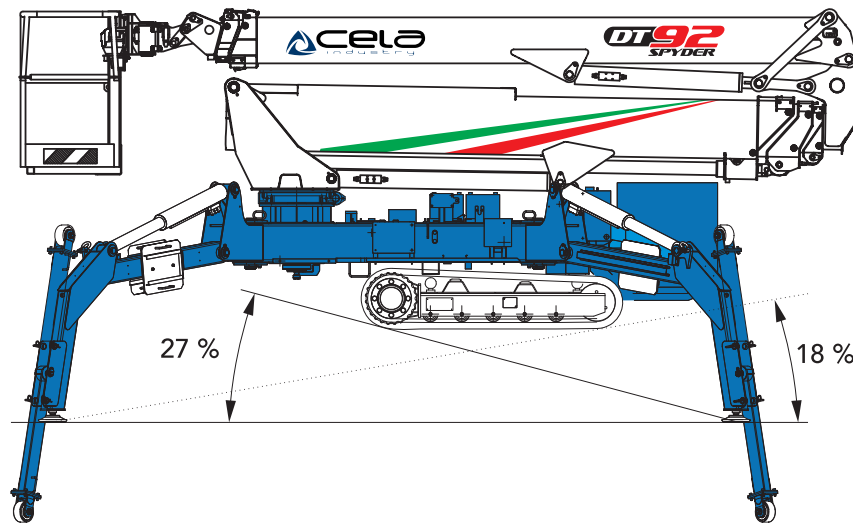
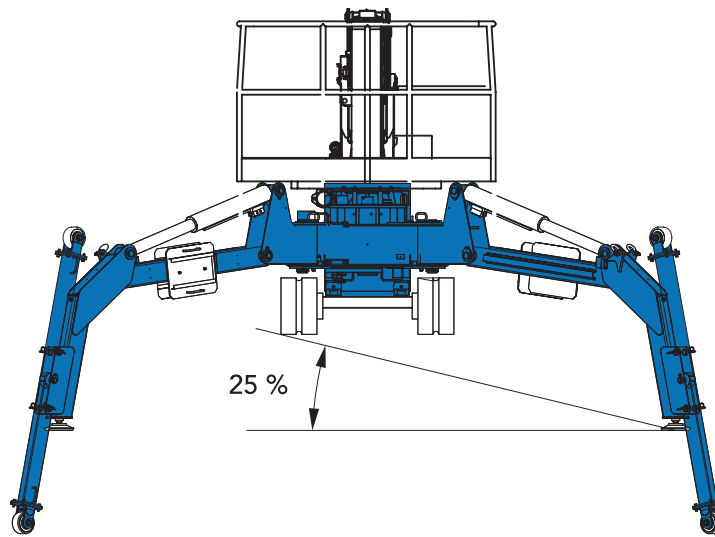
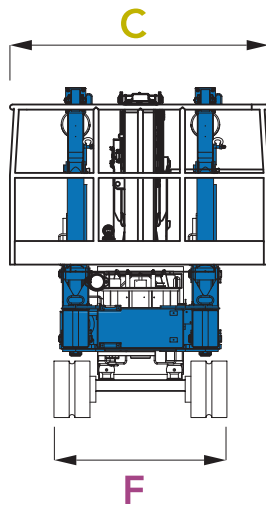
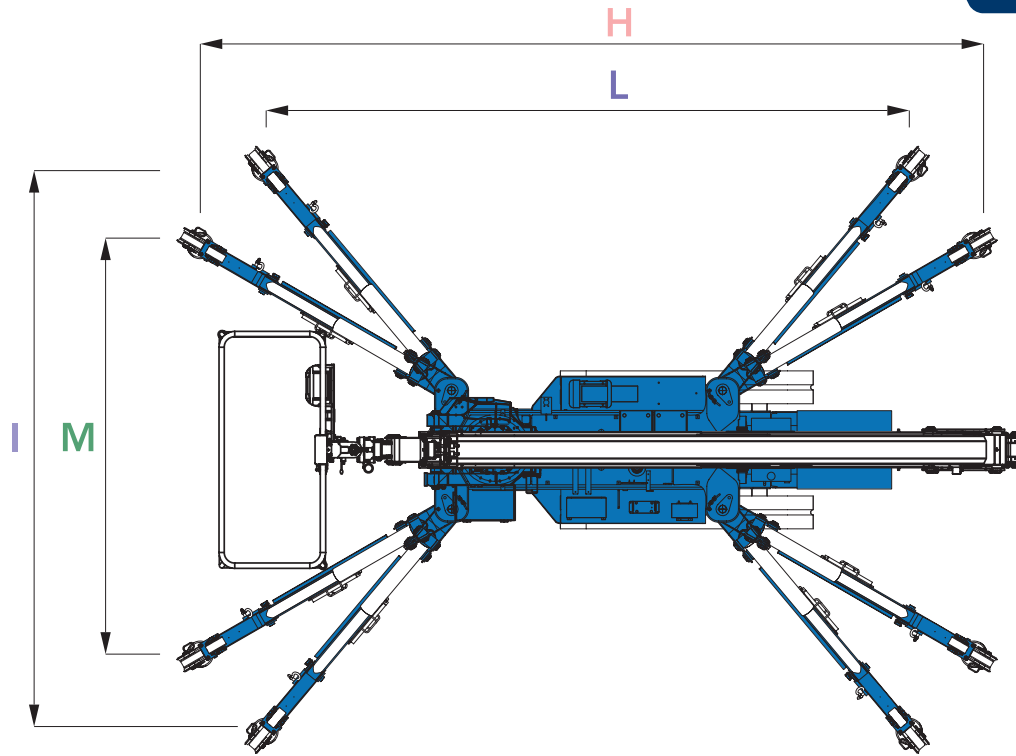

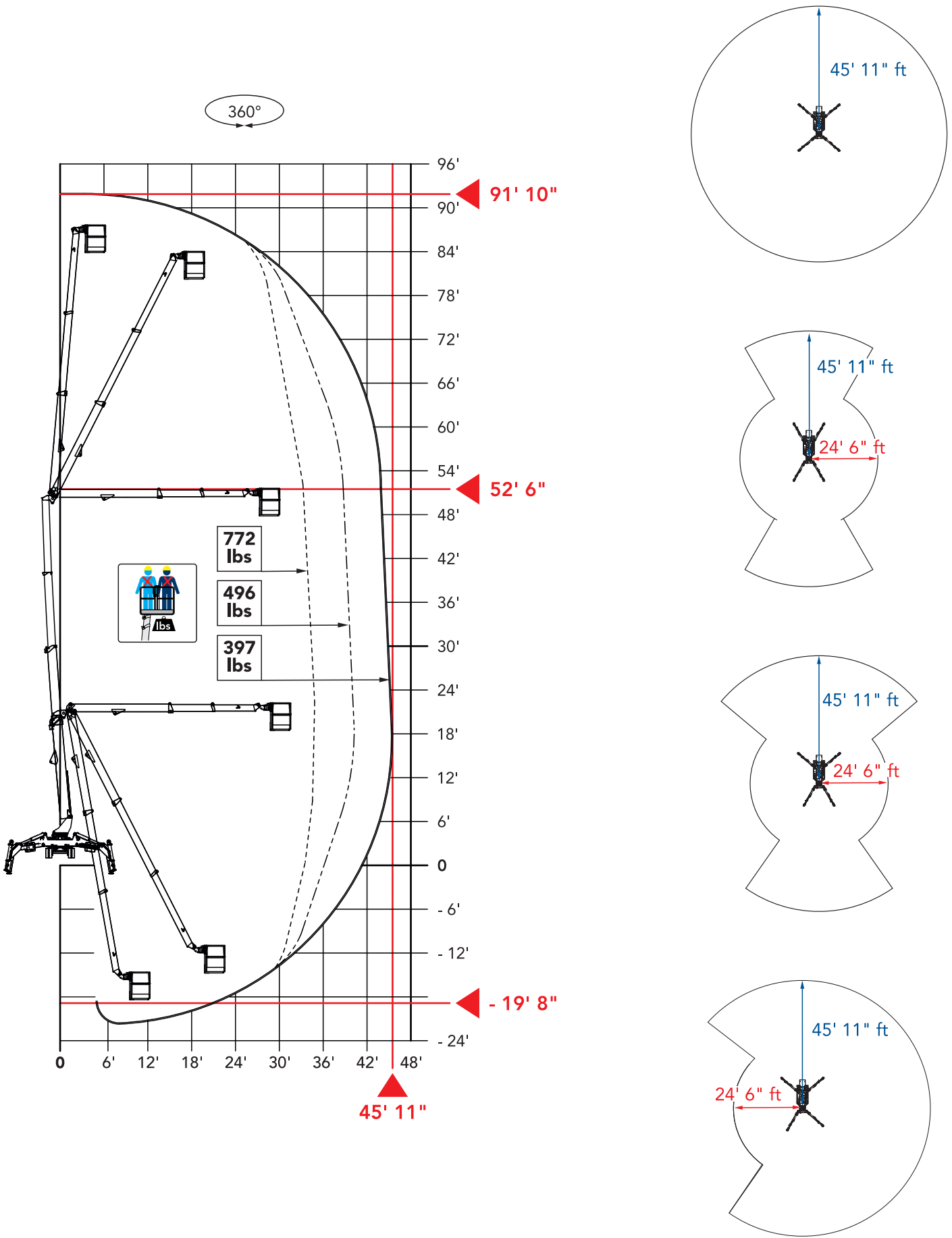

UP & OVER - MARKET LEADING

We fly all over

45' 11" ft →

↑ **52' 6" ft**

Authorized height landing

Multipurpose lifting options

2' 3" ft

4' 6" ft

5' 9" ft

7' 9" ft

Like an elevator

52' 6" ft

